



Experimental Investigation on Carbon Dioxide Reduction by Using Post Combustion Carbon Capture System in a Spark Ignition Engine

Santosh P¹ , Vinith Kumar A²

¹Research Scholar, Department of Mechanical Engineering, Anna University, Guindy, Chennai, Tamil Nadu, India

²Assistant Professor, Department of Mechanical Engineering, Chennai Institute of Technology, Kandrathur, Chennai, Tamil Nadu, India

Emails: santoshsj1996@gmail.com , vinithkumara@citchennai.net

Article History

Received: 8 March 2022

Accepted: 22 April 2022

Keywords:

Petrol engine;

Gasoline as fuel;

Carbon dioxide reduction;

Monoethanolamine

Abstract

Global warming is a serious environmental concern that affects humans, wildlife, and ecosystems. Carbon dioxide reduction is the need of the hour as it a major constituent of global warming. The quantum of carbon dioxide released in the exhaust depends on the number of carbon atoms present in the fuel used. The present study investigates the reduction of engine out carbon dioxide emission. For carbon dioxide reduction post combustion capture system is used. In post combustion capture system carbon dioxide is absorbed by using absorption catalyst. In this capture system, carbon dioxide is absorbed after the combustion. Among various absorption catalyst, monoethanolamine (MEA) is used, as it can react more quickly with carbon dioxide than other absorbents. Monoethanolamine is continuously injected in the exhaust manifold. Empty chamber is added in the exhaust manifold for increasing the resident time of the reaction of amine with carbon dioxide. MEA reacts with carbon dioxide forms ammonium carbamate. Carbamate is approved by the Environmental Protection Agency as an inert ingredient, used for insect and rodent control in areas where agricultural products are stored.

1. Introduction

Global carbon dioxide levels have been rising since the beginning of the industrial revolution, around 1750. Anthropogenic CO_2 emissions, mostly from the combustion of fossil fuels for energy, have been blamed for the rise, and the pace of growth has accelerated as fossil fuel consumption has increased. Higher CO_2 concentrations have resulted in a number of environmental challenges, the most notable of which is an increase in global temperatures, sometimes known as global warming. As a result, challenges like melting snow and ice caps, rising sea levels, and more extreme weather patterns arise. Pre-

venting CO_2 concentrations from rising is viewed as critical in reducing the hazards of global warming. CO_2 is one of the most significant contributors to global warming. Global warming is a huge environmental hazard that affects humans, wildlife, and ecosystems. According to the Intergovernmental Panel on Climate Change (IPCC), the earth's surface temperature will rise by 1–2°C by 2020 and 2–5°C by 2070. Based on economic and environmental factors, efficient and appropriate CO_2 separation technology with low operating costs and energy consumption is required.

One possible strategy is to capture CO_2 in the

combustion site's effluent, a technique known as post combustion CO_2 capture. The removal of CO_2 from stack gas and the simplicity of retrofitting existing CO_2 sources with these technologies are among the technologies being explored. The use of carbon capture and storage (CCS) to reduce CO_2 emissions from fossil-fuel-fired power stations and industrial sources is a hot topic of controversy around the world. CCS is a technology option that could help to achieve the UNFCCC's goal of reducing greenhouse gas (GHG) emissions from fuel gas by 50–85 percent by 2050 (UNFCCC, 2009).

Post-combustion CO_2 capture, pre-combustion CO_2 collection, and oxy-fuel combustion are the three types of technologies used to remediate anthropogenic CO_2 . In post-combustion technology, fossil fuels are burned in the same way they are in traditional energy generation, but CO_2 is recovered from the effluent gas. Because it can be retrofitted to existing power plants, this intuitive technique is being examined extensively.

The fossil fuel is gasified and reacts in a water gas shift reactor to produce H_2 and CO_2 in pre-combustion CO_2 capture. The CO_2 is captured, and the H_2 is used to generate energy. Pure or virtually pure O_2 is used in oxy-fuel combustion, resulting in mostly CO_2 and H_2O being generated.

Post-combustion CO_2 capture is the most researched among the three types because separating CO_2 at the combustion exhaust allows for simple and intuitive retrofitting of existing CO_2 sources. Because it is flexible and does not require changing the combustion cycle, post-combustion capture is a critical technique for reducing CO_2 emissions.

For CO_2 scrubbing, a variety of absorption catalysts such as mono ethanol amine (MEA), succinic acid, anhydrous ammonia, and diethyl amine are utilised.

Mono Ethanol Amine (MEA) is the most essential and widely utilised of three different absorbents for CO_2 separation. MEA reacts with CO_2 more quickly than other absorbents. Aqueous amine solutions, such as mono ethanol amine, are used to scrub carbon dioxide. Mono ethanol amine (MEA) is pumped into the engine's exhaust manifold.

Author evaluated the kinetics of several amines to MEA and concluded that MEA has the highest CO_2 absorption capacity at room temperature, which occurs after five minutes of reaction. In

this current work MEA is injected to the engine-out emission and the respective changes are observed. They also reported that MEA reacts with CO_2 and forms ammonium carbamate. (Dibenedetto, Aresta, and Narracci)

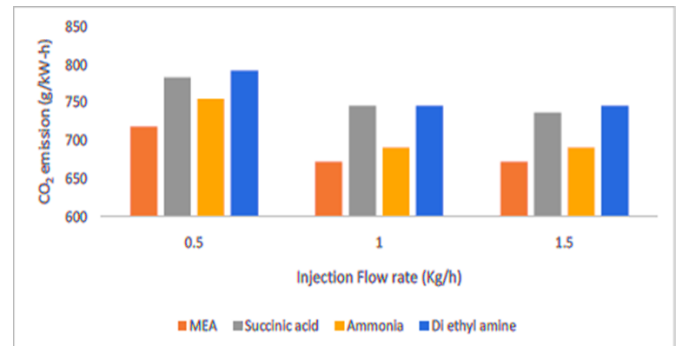

FIGURE 1. Comparison of CO_2 Emission for Various Liquid Absorption Catalyst at Different Injection Rates

Based on analysis (Subramanian, Varuvel, and Martin) with various absorption catalysts like MEA, succinic acid, anhydrous Ammonia and diethyl amine by injecting it in the exhaust manifold, maximum CO_2 reduction occurs with MEA injection than other catalysts as shown in fig. 1.

2. Experimental setup

A single cylinder four stroke air cooled naturally aspirated spark ignition engine with developing capacity of 4.1kW power at 3,600 rpm was used for the experimentation. The engine specifications are given in table 1.

Engine is coupled with eddy current dynamometer for loading. No Internal modification is done on the engine since the focus is on post combustion carbon dioxide capture, the exhaust manifold is alone modified and a separate MEA injector is placed (Sood and Vyas Lv, Guo, and Zhou I Huertas et al.)

An auxiliary injection system for amine injection is to be placed at the exhaust manifold. The injection pump is mechanical type connected to motor and rotates at 1,500 rpm which ensures continuous injection of amine in the exhaust manifold (Fan, Russell, and Dutcher Luis)

In Figure 2. the following is labelled as 1.Engine; 2.Eddy current dynamometer; 3.Air box; 4.Surge tank; 5. Fuel filter; 6.Carburator; 7. Spark plug;

TABLE 1. Engine Specification

Engine Type	4 – Stroke single cylinder, OHV petrol engine
Bore x stroke (mm)	68 x 54
Displacement (cc)	196
Compression ratio	8.5: 1
Net power	4.1 kW @ 3500 rpm

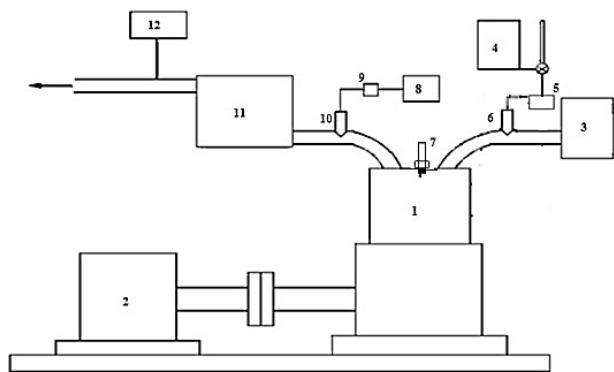

FIGURE 2. Overview of Engine setup



FIGURE 3. Pictorial View of SI Engine

8.Motor for MEA injection; 9.Pump for MEA system; 10 Injector for MEA; 11. Empty chamber; 12.AVL gas analyzer

An empty chamber of five litres capacity is connected to the exhaust manifold to expand the retention time for completing the reaction of exhaust gas and amine mixture (H. R. Kalatjari et al. Mousavian et al. A. H. R. Kalatjari et al.) . Fig. 2 shows the experimental setup of amine injection at exhaust. Surge tank is used to give a constant amount of air supply to the engine. Load is measured using eddy current dynamometer. For various loads, 0%, 25%, 50%, 75%, 100% the carbon dioxide emission is measured using AVL gas analyzer.

In Figure 3. the following is labelled as 1 is Surge Tank, 2 is Exhaust, 3 is Eddy current dynamometer and 4 Single cylinder Petrol engine.

3. Load Measurement

The engine is coupled with an eddy current dynamometer for loading. Eddy current dynamometer consists of a rotor, stator poles, stator casing. Rotor is connected to the engine crankshaft and it rotates within the stator poles, DC voltage is applied to the stator casing. Rotor is rotating with the help of engine shaft and voltage is applied to coil or stator casing.

Due to this, magnetic flux is generated and rotor

cut this magnetic flux and hence eddy current will be produced in the rotor which opposes the change in magnetic flux. Due to this rotor gets opposing force which tries to reduce the rpm of the rotor. But torque supplied by the engine will maintain the rpm (Ahmad et al. Lee, Kolawole, and Attidekou)

4. Exhaust Gas Temperature Measurement

Exhaust gas temperature is measured by using K - type thermocouple which is mounted in the exhaust line. The thermocouple is connected to temperature indicators. Type K is the widely used thermocouple that has a range of 270° to 1260° C.

5. Emission Measurement System

The carbon dioxide emissions from various loads is taken in two ways, with and without Mono Ethanol Amine injection. In this current work, the exhaust emissions such as CO, HC, from an engine has been measured by the HORIBA MEXA-584L exhaust gas analyzer (Mun et al.).

6. Methodology

The experiment is to be carried out on a single cylinder naturally aspirated air-cooled SI engine.

i) An auxiliary injection system for MEA injection is placed at the exhaust manifold. The MEA



FIGURE 4. ECU to Control MEA Injection

injection system consists of an ECU, injector, proximity sensor, switched mode power supply.

ii) The MEA injection pump is a mechanical submersible low pressure pump which is connected to MEA tank.

iii) When exhaust valve opens, certain point on shaft coupling passes the proximity sensor and screw is welded on that point.

iv) When screw on coupling passes the proximity sensor, the sensor gives signal to ECU that exhaust valve is open. Then ECU will active injector to inject MEA.

6.1. Shaft Coupling Modification

i) Certain point on shaft coupling passes the proximity sensor when exhaust valve opens.

ii) That point is marked and screw is welded on it. Proximity sensor detect the presence of nearby object without any physical contact.

iii) Thus, when the screw on coupling passes the sensor, it gives signal to ECU that exhaust valve is open. Then ECU will activate injector to inject MEA for 246° crank angle (exhaust duration).

6.2. ECU

ECU receives input signal from proximity sensor and send the output signal to injector to inject MEA for 246° crank angle (exhaust duration). Fig. 4 displays the ECU used in this current work to control MEA injection.

6.3. Fuel Injector

Injector is used to inject MEA at the exhaust manifold. Injector is attached to injector holder and it is connected to the exhaust manifold of the engine.

MEA is injected to the exhaust gases at a constant

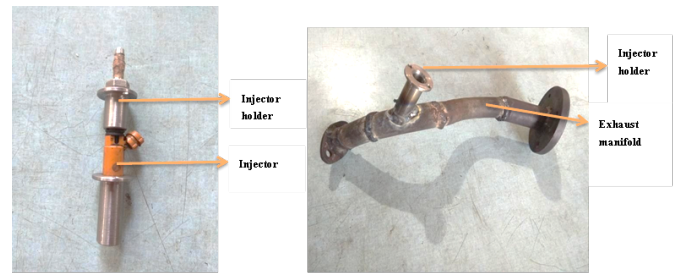

FIGURE 5. Injector with Injector Holder

flowrate of 1 kg/h. Fig. 5 shows the injector which is held using injector holder.

6.4. Modified Exhaust Manifold

The exhaust manifold of test engine is modified by fitting injector to it (Khoshraftar and Ghaemi). The injector is connected with submersible low-pressure pump and MEA tank. The injector is used to inject MEA to the exhaust gas. Injector holder is welded to the manifold with 45° for better mixing. Exhaust manifold is modified in a way favorable for MEA injection. The injector holder is welded at the Exhaust manifold as shown in fig.6

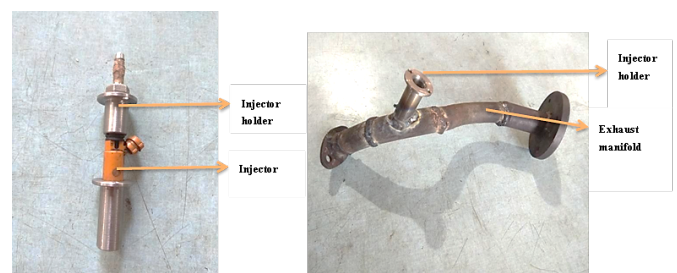

FIGURE 6. Modified Exhaust Manifold containing Injector holder



FIGURE 7. Pictorial View of Modified Exhaust

6.5. Submersible Low-Pressure Pump

MEA is kept in a separate tank and pumped using a submersible pump. Fig. 8 shows the submersible low-pressure pump used in this current work. The tank is properly closed and the submersible fuel pump is kept inside (Makertihartha et al.) . Through SMPS a 5V constant supply is delivered to the pump.



FIGURE 8. Submersible Fuel Pump for MEA

6.6. Circuit Diagram

The circuit diagram connecting ECU, proximity sensor and injector is shown in fig. 9. To get a constant 12V supply SMPS is employed in this current work.

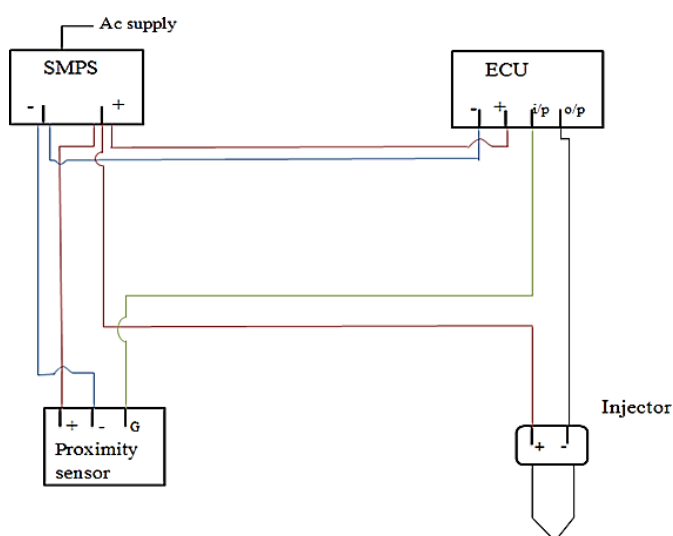

FIGURE 9. Circuit Diagram connecting ECU, Proximity sensor and injector

7. Results and Analysis

MEA was injected in the exhaust manifold at constant flow rate of 1 kg/h. Emission parameters like CO_2 , CO, HC and NO are to be tested in all the phases at part load and full load conditions.

MEA injection in exhaust with injection rate of 1 kg/h is optimum compared to other absorption catalysts like Succinic acid, anhydrous ammonia and Di ethyl amine based on minimum CO_2 emission. The exhaust emissions such as HC, CO, NOX, CO_2 from SI engine are measured with gasoline as engine fuel by using AVL gas analyzer. Since the main focus is on carbon dioxide, the comparison of with and without MEA injection with engine out emission is studied. The emissions are measured with constant speed 3000 rpm and with various loads 0%, 25%, 50%, 75% and 100%.

The graph is drawn with BMEP in x axis and CO_2 emission in y axis. CO_2 emission increases with increase in load for a constant speed of 3000 rpm. The graph is drawn with a comparison of injecting MEA with not injecting MEA. The respective changes in carbon dioxide are observed. From fig. 10, we could see a significant decrease in the percentage of carbon dioxide with the injection of MEA.

On varying the injection quantity and injection rate with different injection angles may help to observe the adsorption process of carbon dioxide with MEA injection. Thus, with MEA injection in the exhaust may help to reduce Carbon dioxide emission to greater extent if proper injection parameters are fixed.

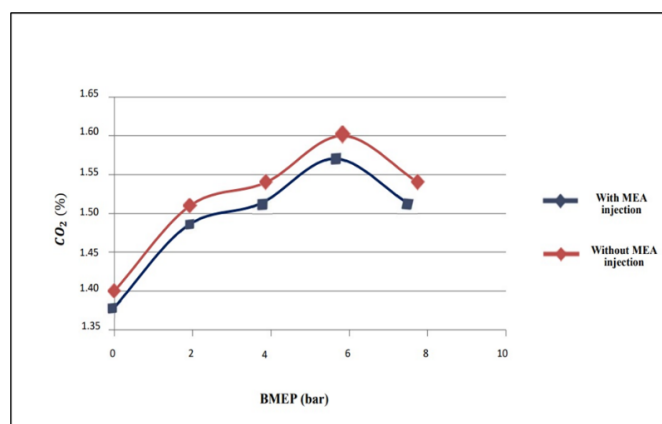

FIGURE 10. CO_2 Vs BMEP

Along with After-Treatment devices, MEA injection is also preferred to meet the near future emission norms. MEA injection can also be used in

advanced combustion concepts called low temperature combustion processes, as the carbon dioxide emission is obtained more in those combustion processes.

8. Conclusion

Gasoline is used as engine fuel and for effective CO_2 reduction post combustion carbon capture system is used. In post combustion carbon capture system CO_2 is captured after the combustion process. This process uses various absorption catalysts to capture CO_2 . Among those catalyst Monoethanolamine (MEA) is chosen, as MEA cost is lesser and has the ability to react quickly with CO_2 than other absorbent. MEA is injected in the exhaust manifold of the engine. For which auxiliary injection system for mono ethanol amine injection is placed at the exhaust manifold. MEA reacts with CO_2 forms ammonium carbamate. Thus, causes reduction in CO_2 emission. The CO, HC, NO and CO_2 emissions are measured using AVL five gas analyzer with gasoline as SI engine fuel. From fig.10 we could observe significant decrease in the percentage of CO_2 by the injection of MEA to the exhaust gases. Altering the injection angle and injection quantity of MEA may result in much more decrease in the percentage of CO_2 .

ORCID iDs

Santosh P  <https://orcid.org/0000-0002-0594-0478>

References

- Ahmad, Adrianto, et al. "Determination of mass transfer coefficient from biogas purification process by mono ethanol amine (MEA)". *Materials Today: Proceedings* (2022). [10.1016/j.matpr.2022.02.430](https://doi.org/10.1016/j.matpr.2022.02.430).
- Dibenedetto, A, M Aresta, and M Narracci. "Carbon dioxide capture by amines: Increasing the efficiency by amine structure modification". *ACS Division of Fuel Chemistry* (2002): 47–53.
- Fan, Maohong, Armistead G Russell, and Bryce Dutcher. "Amine-Based CO_2 Capture Technology Development". *AIP Conference Proceedings* 7 (2015): 2137–2148. [10.1021/am507465f](https://doi.org/10.1021/am507465f).

- I Huertas, Jose, et al. "CO₂ Absorbing Capacity of MEA". *Journal of Chemistry* (2015). [10.1155/2015/965015](https://doi.org/10.1155/2015/965015).
- Kalatjari, Ali Hamid Reza, et al. "Experimental and modeling using a generalized Patel- Teja – Valderrama equation of state for computation of mono ethanol amine(MEA) solution density in a CO₂ capturing pilot plant". *Fluid Phase Equilibria* 25 (2020). [10.1016/j.fluid.2020.112803](https://doi.org/10.1016/j.fluid.2020.112803).
- Kalatjari, Hamid Reza, et al. "Experimental, simulation and thermodynamic modeling of an acid gas removal pilot plant for CO₂ capturing by mono-ethanol amine solution". *Journal of Natural Gas Science and Engineering* 72 (2019): 103001–103001. [10.1016/j.jngse.2019.103001](https://doi.org/10.1016/j.jngse.2019.103001).
- Khoshraftar, Zohreh and Ahad Ghaemi. "Presence of activated carbon particles from waste walnut shell as a biosorbent in monoethanolamine (MEA) solution to enhance carbon dioxide absorption". *Heliyon* 8.1 (2022): e08689–e08689. [10.1016/j.heliyon.2021.e08689](https://doi.org/10.1016/j.heliyon.2021.e08689).
- Lee, Jonathan, Toluwanimi Kolawole, and Pierrot Attidekou. "Carbon Capture from a Simulated Flue Gas Using a Rotating Packed Bed Adsorber and Mono Ethanol Amine (MEA)". *Energy Procedia* 114 (2017): 1834–1840. [10.1016/j.egypro.2017.03.1312](https://doi.org/10.1016/j.egypro.2017.03.1312).
- Luis, Patricia. "Use of mono ethanol amine (MEA) for CO₂ capture in a global scenario: Consequences and alternatives". *Desalination* 380 (2016): 93–99. [10.1016/j.desal.2015.08.004](https://doi.org/10.1016/j.desal.2015.08.004).
- Lv, Bihong, Bingsong Guo, and Zuoming Zhou. "Mechanisms of CO₂ Capture into MEA Solution with different CO₂ Loading during the Absorption / Desorption Processes". *Environmental Science and Technology* 49 (2015): 10728–10735. [10.1021/acs.est.5b02356](https://doi.org/10.1021/acs.est.5b02356).
- Makertihartha, I. G. B. N., et al. "Post combustion CO₂ capture using zeolite membrane". *AIP Conference Proceedings* (2017). [10.1063/1.4979941](https://doi.org/10.1063/1.4979941).
- Mousavian, Parham Seyedsaman, et al. "Modeling and simulation absorption of CO₂ using hollow fiber membranes(HFM) with mono-ethanol amine with computational fluid dynamics". *Journal of Environmental Chemical Engineering* 8 (2020). [10.1016/j.jece.2020.103946](https://doi.org/10.1016/j.jece.2020.103946).

Mun, Ji-Hun, et al. "Optimal MEA/DIPA/water blending ratio for minimizing regeneration energy in absorption-based carbon capture process: Experimental CO₂ solubility and thermodynamic modeling". *Chemical Engineering Journal* 444 (2022): 136523–136523. [10.1016/j.cej.2022.136523](https://doi.org/10.1016/j.cej.2022.136523).

Sood, Akash and Savita Vyas. "Carbon dioxide capture efficiency determination for post combustion capture through MEA using Aspen HYSYS at low pressure". *International Conference on Energy, Communication, Data Analytics and Soft Computing (ICECDS)* (2017). [10.1109/ICECDS.2017.8389738](https://doi.org/10.1109/ICECDS.2017.8389738).

Subramanian, Thiyagarajan, Edwin Geo Varuvel, and Leenus Jesu Martin. "Experimental investigation to reduce CO₂ emission in a single cylinder CI engine using low carbon fuel blend with Karanja oil methyl ester and amine injection in the exhaust manifold". *International journal of Global Warming* (2015). [10.1504/IJGW.2017.10007767](https://doi.org/10.1504/IJGW.2017.10007767).



© Santosh P et al. 2022 Open Access. This article is distributed under the terms of the Creative Commons Attribution 4.0 International License (<http://creativecommons.org/licenses/by/4.0/>), which permits unrestricted use, distribution, and reproduction in any medium, provided you give appropriate credit to the original author(s) and the source, provide a link to the Creative Commons license, and indicate if changes were made.

Embargo period: The article has no embargo period.

To cite this Article: P, Santosh, and Vinith Kumar A. "Experimental Investigation on Carbon Dioxide Reduction by Using Post Combustion Carbon Capture System in a Spark Ignition Engine." *International Research Journal on Advanced Science Hub* 04.04 April (2022): 94–100. <http://dx.doi.org/10.47392/irjash.2022.024>